

VAYARA Group

Excellence in plastic film and
packaging solution

www.vayaragroup.com



Our Products

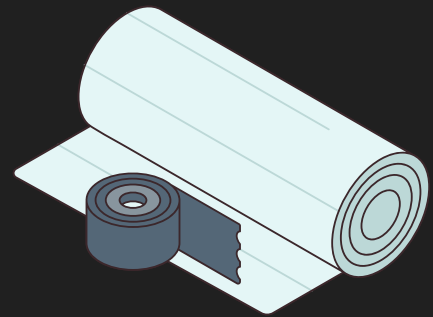

- Mulching Film
- Stretch Film
- Shrink Film
- Polyethylene (LDPE) Film / Bags
- Anti-Static Films / Bags (for Food & Pharmaceutical industries)
- Tarpaulin
- Surface Protection Film
- Cling Film
- Air Bubble Film
- Packing Straps (Polypropylene / PET)
- Woven Fabrics (Polypropylene / HDPE)

Mulching Film

Mulching has become the core technology in vegetables, fruits, flowers and foodgrains production as the quality of the crop is far more superior and yield is faster. Made from durable polyethylene, our mulch film is a high-quality agricultural covering designed to enhance soil health and promote plant growth.

Discover numerous advantages of our mulch film

- **Better Crop Growth:** Maintain optimal soil temperature and moisture levels, promoting healthier and faster plant growth
- **Water Conservation:** Reduces evaporation and water wastage, ensuring efficient irrigation and lower water costs.
- **Weed Control:** Acts as a barrier against weeds, eliminating the need for frequent weeding and reducing herbicide expenses.
- **Improved Soil Health:** Prevents soil erosion and enhances nutrient retention, ensuring long-term soil fertility.
- **Protection from Pests & Diseases:** Reduces direct contact between soil and crops, minimizing the risk of fungal infections and pests.

Specifications

Thickness	15 to 100 micron	Length	As required
Width	400mm to 1500mm	UV Protection	Yes
Perforation	As required	Printing	As required

Black & Silver/White



Transparent



Blue



Red



Stretch Film

02

Our Stretch Film is designed for high efficiency wrapping, providing superior load stability & high tear resistance. It offers exceptional stretchability, reducing material usage while ensuring secure, damage-free transport and storage of products.

Our Offerings

VCI Stretch Film
(Rust Prevention)



Machine Grade Stretch Film
(Efficient Packaging)



Hand Grade Stretch Film
(For Manual packaging)



UVI Stretch Film
(UV Protection Feature)



Specifications

Thickness	15 to 100 micron	Length	As required
Width	75mm to 1500mm	Colour	All Colours available
Cling	Inside	Printing	Available

Shrink Film

Vayara’s Shrink Film is a flexible, durable packaging material that shrinks tightly around products when heated, creating a secure, tamper-evident seal. It offers excellent protection, maintaining product integrity during transportation and storage.

Advantages of our shrink film

- **High Strength & Durability:** Provides strong protection against tearing, puncturing, and external damage.
- **Excellent Shrinkage:** Offers tight wrapping around products for secure packaging and stability.
- **Moisture & Dust Resistant:** Protects goods from water, dust, and environmental contaminants.
- **Ideal for Heavy & Bulky Products:** Suitable for pallet wrapping, industrial goods, and large items.
- **Cost-Effective:** Reduces packaging costs while ensuring product safety and efficiency.

Specifications

Thickness	51 to 300 micron
Width	400mm to 1500mm
Length	As required
Colour	All colours available
UV Protection	Available
Anti Corrosive	Available

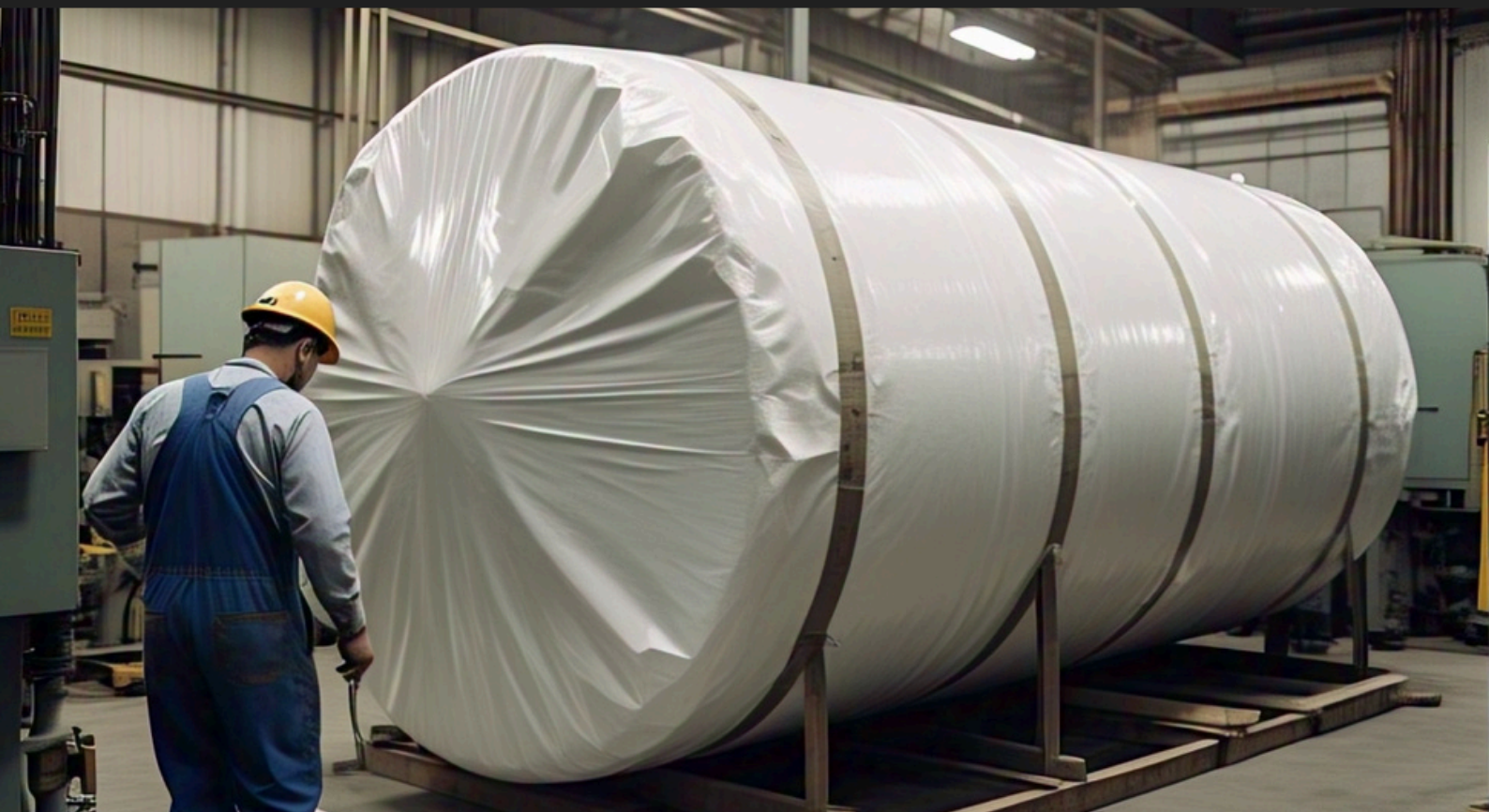

Polythene Film/Bag

04

Our Polyethylene Films and Bags offer a versatile, cost-effective solution for packaging, storage, and transportation needs. Made from high quality raw material, these films and bags provide excellent strength, durability and moisture resistance, making them ideal for a wide range of industries including retail and logistics.

VCI bags/films
(Anti-Corrosive)



Coloured polythene bags/films



Milk Pouches
(Leak Proof)



Garbage Bags



Anti-Static Film/Bag

05

We manufacture bags for pharmaceutical and food packaging industries, which require strict adherence to exact specifications and the highest quality. All of our bags are manufactured with 100% prime virgin raw material using good manufacturing practices. These bags allow seamless transfer of material & help prevent loss of material stuck to poly bag due to static charges.

Pharmaceutical APIs & powders



Food ingredients



Static sensitive electronic devices



Medical Devices



Tarpaulins

06

Tarpaulin is a robust and versatile polyethylene-based material designed for heavy-duty applications. This high-performance film provides exceptional strength, tear resistance, and weather protection, making it ideal for a variety of industrial and commercial uses

Benefits of our tarpaulins

- **Waterproof or water-resistant:** Made from polyethylene that prevent water from passing through.
- **Durable:** Constructed to withstand harsh weather conditions, heavy use, and rough handling.
- **Flexible:** Can be easily folded, rolled, or draped over objects.
- **Portable:** Lightweight and easy to transport.
- **UV Resistance:** They're treated to resist UV radiation, preventing damage from prolonged sun exposure.
- **Chemical Resistance:** Our tarpaulins are resistant to many chemicals, oils, and acids.



HDPE Tarpaulin

- More Durable
- Better chemical resistance
- Ideal for large equipments



LDPE Tarpaulin

- Cost effective
- Better flexibility
- ideal for smaller equipments

Packing Strap

07

Polypropylene (PP) Strap



Uses

- Suitable for packaging small to medium-sized boxes, pallets, and bundles.
- Used for securing hay bales, lumber, and other agricultural products.
- Used for bundling fabrics, garments, and other textile products.

Benefits

- Cost-effective compared to PET straps.
- Easy to use
- Corrosion-resistant: Resistant to moisture, chemicals, and UV light.
- Customizable: Available in various colors, embossing, and printing options.

Uses

- Suitable for packaging large, heavy, or irregularly shaped products.
- Used for securing pipes, tubes, and other industrial products.
- Used for securing cargo for export, due to its high strength and durability.

Benefits

- Offers superior strength and durability compared to PP straps.
- PET straps are less prone to stretching and deformation.
- Provides a tighter, more secure seal.
- PET straps can withstand harsh environments and last longer.

PET Strap



Woven Fabric

- **Agricultural packaging:** Commonly used to package agricultural products such as grains, seeds, and fertilizers.
- **Food packaging:** Used to package food products such as sugar, flour, and coffee.
- **Construction materials:** Used to package construction materials such as cement, sand, and aggregates.
- **Industrial packaging:** Used to package industrial products such as chemicals, minerals, and machinery parts.
- **Cost-effective:** Less expensive than HDPE.
- **Breathable:** More breathable than HDPE, making them suitable for packaging dry goods.

Polypropylene (PP) fabric / bags



HDPE fabric fabric / bags



- **Heavy-duty packaging:** Used for heavy-duty packaging applications such as mining, construction, and water treatment.
- **Chemical packaging:** Used to pack chemicals, oils, and greases due to their excellent chemical resistance.
- **UV-resistant applications:** Used in applications where UV resistance is critical, such as outdoor storage or transportation.
- **Durable:** More durable and less prone to tears and punctures than PP.
- **Long-lasting:** Have a longer lifespan than PP due to their excellent UV resistance and chemical resistance.

Surface Protection Film



Surface Protection Film is a high-performance, self-adhesive film designed to safeguard surfaces during manufacturing, transportation, and installation. It provides an effective, temporary layer that shields against scratches, dust, dirt, and other potential damage, ensuring that your products maintain their pristine condition.

Cling Film is a robust, high-performance wrap designed for commercial and industrial applications. Made from durable PVC or polyethylene, it offers superior stretchability, excellent cling, and reliable moisture resistance. Available in various widths and thicknesses to meet the specific needs of different industries.

Cling Film



Air Bubble Roll

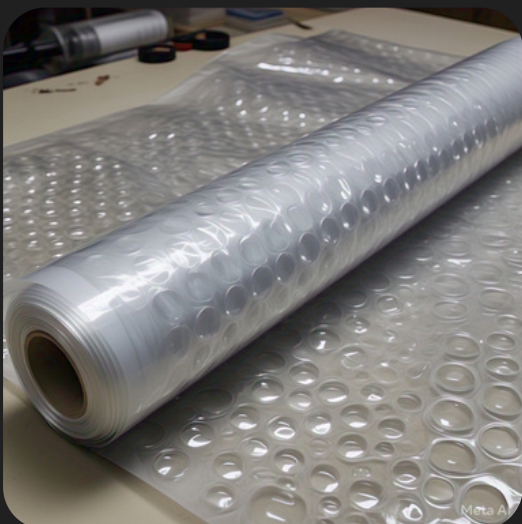

Air Bubble offers reliable protection for fragile items during shipping and storage. Made from high-quality polyethylene, this bubble wrap is lightweight, durable, and designed to absorb shocks, reduce vibration, and prevent scratches.

VAYARA Group

Excellence in plastic films
and packaging solutions



Join us in shaping the future



+91 9370707755



varune@vayaragroup.com